

Phased Out specifications part 1: Materials

All canvas materials for the tent must meet the specifications below and ISO 10966.

Information for testing:

Two complete tents must be sent as a sample to the laboratory.

The test pieces will be cut from one complete tent.

The second complete tent will be used for the rain test.

A product is deemed acceptable only if the same sample passes all criteria.

<i>1.1 Specifications for the outer-tent roof canvas</i>	
Type and norms	Required minimum values
1. Composition ISO 1833	Polyester and cotton blended fibres yarns. cotton: 40% (± 10), polyester: 60% (± 10) i.e., 50 to 70% polyester, with balance in cotton
2. Specific weight (g/m ²) ISO 3801	350g/m ² ($\pm 15\%$) in finished state.
3. Colour	Natural white, not dyed
4. Water-vapour permeability ISO 17229	Minimum 2000g/m ² /24h
5. Tensile strength (N) Apply ISO 13934-1 to 10 test pieces of plain canvas. Apply ISO 13935-1 on 5 test pieces with seams, cut from the tent perpendicular to the seam, in the roof.	Warp and weft 850N minimum. For plain canvas test: 5 test pieces in warp direction, 5 test pieces in weft. On seams, the test is applied to 50mm width on the sample, as described in ISO 13935-1 page 7.
6. Tear resistance, started (N) –ISO 9073-4	Warp and weft 60N minimum.
7. Water-penetration resistance ISO 811 Test pieces of plain canvas.	30hPa minimum, increasing speed at 100mm per minute.
8. Rain-penetration resistance ISO 5912:2003 The test piece is the complete tent. (attention: ISO 5912:2011 does not apply) Outer tent: There should be not more than 10 drops of water in maximum 2 places, penetrating inside the outer tent, including through wick effect. Only the 4 places at the top of the door poles may have some leakages through the eyelets. Inner tent: There should be not water penetrating inside the inner tent, or wetting the inner tent canvas.	Apply procedure as per point 4.2.11 in ISO 5912:2003 in point 5.6 plus following: A visual control from the inside of the tent, while the artificial rain is on, must be done after 2h and 5h, with the complete tent. The test operator should ensure that the set up of the test will not create condensation inside the tent that could be interpreted as leakages.

9. Dimensional variation when soaked in water ISO 7771	Maximum 3%
10. Tensile strength resistance after exposure to micro-organisms under ISO 13934-1 and ISO 13935-1 after completing BS 6085 (soil burial - 28 days). Apply on 10 test pieces of plain canvas and 5 test pieces with seams.	30% maximum strength-loss on minimum required value and 50% maximum strength-loss on original value of the same product. For plain canvas test: 5 test pieces in warp direction, 5 test pieces in weft. On seams, the test is applied to 50mm width on the sample, as described in ISO 13935-1 page 7.
11. Efficiency of water-repellent treatments after soaking in water. Same test as point 7, on samples soaked in water under ISO7771 without wetting agent.	30hPa minimum, increasing speed at 100mm per minute.
12. Efficiency of fungicides product after soaking in water. Same test as point 10, on samples soaked in water under ISO7771 without wetting agent.	10% maximum additional loss as compared to the results from point 10.
13. Tensile strength after exposure to UV and moisturizing (climatic simulation). Exposure in a climatic chamber under ISO 4892-2, type A, 360 hours, followed by tensile test under ISO13934-1.	30% maximum strength-loss on minimum required value and 50% maximum strength-loss on original value of the same product. Number of test pieces: 3 test pieces in warp direction, and 3 test pieces in weft.

1.2 Specifications for the outer-tent wall canvas	
Type and norms	Required minimum values
1. Composition ISO 1833	Poly ester and cotton blended fibres yarns cotton: 40% (± 10), polyester: 60% (± 10) i.e., 50 to 70% polyester with balance in cotton.
2. Specific weight (g/m ²) ISO 3801	200 g/m ² ($\pm 10\%$) in finished state.
3. Colour	Natural white, not dyed.
4. Water-vapour permeability ISO 17229	Minimum 2000g/m ² /24h.
5. Tensile strength (N) Apply ISO 13934-1 on 10 test pieces of plain canvas. Apply ISO 13935-1 on 5 test pieces with seams, cut from the tent perpendicular to the seam.	Warp and weft 650N minimum. For plain canvas test: 5 test pieces in warp direction, 5 test pieces in weft. On seams, the test is applied to 50mm width on the sample, as described in ISO 13935-1 page 7.

6. Tear resistance, started (N) ISO 9073-4	Warp and Weft 40N minimum.
7. Water-penetration resistance ISO 811 Test pieces of plain canvas.	20hPa minimum, increasing speed at 100mm per minute
8. Dimensional variation when soaked in water ISO 7771	Maximum 3%
9. Tensile strength resistance after exposure to micro-organisms under ISO 13934-1 and ISO 13935-1 after BS6085 (soil burial - 28 days). Apply on 10 test pieces of plain canvas and 5 test pieces with seams.	30% maximum strength-loss on minimum required value and 50% maximum strength-loss on original value of the same product. For plain canvas test: 5 test pieces in warp direction, 5 test pieces in weft. On seams, the test is applied to 50mm width on the sample, as described in ISO 13935-1 page 7.
10. Efficiency of water-repellent treatments after soaking in water. Same test as point 7, on samples soaked in water under ISO7771 without wetting agent.	20hPa minimum, increasing speed at 100mm per minute.
11. Efficiency of fungicides product after soaking in water. Same test as point 9, on samples soaked in water under ISO7771 without wetting agent.	10% maximum additional loss as compared to the results from point 9.
12. Tensile strength after exposure to UV and moisturizing (climatic simulation). Exposure in a climatic chamber under ISO 4892-2, type A, 360 hours, followed by tensile test under ISO 13934-1.	30% maximum strength-loss on minimum required value and 50% maximum strength-loss on original value of the same product. Number of test pieces: 3 test pieces in warp direction, and 3 test pieces in weft.

<i>1.3 Specifications for the inner tent canvas</i>	
Type and norms	Required minimum values
1. Composition ISO 1833	Polyester and cotton blended fibres yarns cotton: 40%(±10), polyester: 60%(±10) i.e., 50 to 70% polyester with balance in cotton <u>or</u> cotton 100%.
2. Specific weight (g/m ²) ISO 3801	130 g/m ² ±10% in finished state.
3. Colour	Dyed sand or cream colour.
4. Water-vapour permeability ISO 17229	Minimum 2000g/m ² /24h.
5. Tensile strength (N) ISO 13934-1	Warp and weft 300N minimum.
6. Tear resistance, started (N) ISO 9073-4	Warp and weft 20N minimum.
7. Tensile strength resistance after exposure to micro-organisms under ISO 13934-1 after BS	30% maximum strength-loss on minimum required value and 50% maximum strength-loss

6085 (soil burial - 14 days). Apply on 10 test pieces of plain canvas	on original value of the same product. 5 test pieces in warp direction, 5 test pieces in weft
--------------------------------------------------------------------------	--------------------------------------------------------------------------------------------------

1.4 Specifications for mud flap PE fabric	
Specifications for standard IFRC/ICRC plastic sheeting can also apply. In this case the original lab report from the PE factory will be accepted if still valid.	
Type and norms	Required minimum values
1. Composition	Woven, high-density polyethylene black fibres, fabric laminated on both sides with low-density polyethylene coating.
2. Specific weight (g/m ²) ISO 3801	180gr/m ² (±5%)
3. Tensile strength (N) Apply ISO 13934-1 on 10 test pieces of plain PE fabric. Apply ISO 13935-1 on 5 test pieces with seams, cut from the tent perpendicular to the seam, at the junction of PE and canvas.	Warp and weft 650N minimum. Elongation 15% to 25%. For plain PE fabric test: 5 test pieces in warp direction, 5 test pieces in weft. On seams, the test is applied to 50mm width on the sample, as described in ISO 13935-1 page 7.
4. Tear resistance (N) ISO 4674-1 (method B)	Warp 100N minimum, weft 100N minimum.
5. Resistance to micro-organisms	Insensitive to micro-organisms. Not to be tested.
6. UV resistance as percentage of tensile strength-loss under ISO 1421, after 1500 hours UV under ASTM G53/94 (UVB 313nm peak)	30% maximum strength-loss on minimum required value and 50% maximum strength-loss on original value of the same product 5 test pieces in weft direction, 5 test pieces in warp.
7. Colour	White if made with IFRC/ICRC standard plastic sheeting or any other colour except military green, green, brown or various kaki colours.

1.5 Specifications for the groundsheet PE fabric	
Specifications of standard IFRC/ICRC plastic sheeting can also apply. In this case the original lab report from the PE factory will be accepted if still valid.	
The same type of PE as per the one used for the mud flaps can be used for the ground sheet. In	

this case the criteria below do not apply.

Type and norms	Required minimum values
1. Composition	Woven polyethylene fabric, coated on both sides with low-density polyethylene.
2. Specific weight (g/m ²) ISO 3801	180gr/m ² (± 5%)
3. Tensile strength (N) ISO 1421	Warp 300N minimum, weft 300N minimum.
4. Tear resistance (N) ISO 4674-1 (method B)	Warp 60N minimum, weft 60N minimum.
5. Resistance to micro-organisms	Insensitive to micro-organisms. Not to be tested.
6. UV resistance as percentage of tensile strength-loss under ISO 1421 after 300 hours UV under ASTM G53/94 (UVB 313nm peak)	30% maximum strength-loss on minimum required value and 50% maximum strength-loss on original value of the same product. 5 test pieces in weft direction, 5 test pieces in warp
7. Colour	White if made with IFRC/ICRC standard plastic sheeting or any other colour except military-green. green, brown and various kaki colours.

1.6 Specifications for the mosquito net, inner-tent doors and windows

Type and norms	Required minimum values
1. Material ISO 1833, colour	Polyester 100%, or PE 100%, white
2. Fabrication ISO 8388	Warp knitted
3. Denier	75/100 for the polyester 100 to 150 for the PE
4. Filament	Multi-filament 36 or higher for the polyester Monofilament for the PE
5. Mesh size	25 holes/cm ² (156 holes/inch ²)
6. Weight ISO 3801	30 to 40 g/m ² for polyester 40 to 47 g/m ² for PE
7. Shrinkage ISO 5077	5% maximum
8. Bursting strength ISO 13938	250 kPa minimum for polyester 320 kPa minimum for PE

9. Bursting strength after exposure to UV and moisturizing (climatic simulation). Exposure in a climatic chamber under ISO 4892-2, type A, 180 hours, followed by bursting test under ISO 13938	30% maximum strength-loss on minimum required value and 50% maximum strength-loss on original value of the same product. Number of test pieces: 3 test pieces
----------------------------------------------------------------------------------------------------------------------------------------------------------------------------------------------------	------------------------------------------------------------------------------------------------------------------------------------------------------------------

1.7 Specifications for the outer- tent guy points	
Type and norms	Required minimum values
1. Material composition	Polyethylene, polypropylene or polyester ropes, Polyester straps, steel rings, elastic device.
2. Tensile strength (N) ISO 13934 on the samples with a complete guy point ensemble including all of the reinforcement pieces. Refer to note (below).	3000N minimum for the 6 side guy points (3 test pieces). 1400N minimum for 4 other guy points (2 test pieces). Elongation of the elastic device under 1000N: 50mm minimum, 100mm maximum.
3. UV resistance in percentage of tensile strength-loss after exposure in a climatic chamber under ISO 4892-2, type A, 360hours.	30% maximum strength-loss on minimum. required value and 50% maximum strength-loss on original value of the same product 1 test piece at 1400N, 1 test piece at 3000N.
4. Colour	Black ropes and straps, galvanized steel.
<p>Notes for point n°2:</p> <p>Sample size: width 300mm x length 500mm</p> <p>Sample to be cut at the centre guy line for the 6 side points (500mm length includes eave).</p> <p>Samples to be cut on the top corner of the outer doors for the 4 other points.</p> <p>Samples to be folded in order to fit in the traction apparatus so that the entire width of the canvas is submitted to the traction when clamped in the jaw of the apparatus. Samples must include: a canvas section from the tent roof, canvas reinforcements, strap, ring, elastic device, buckle, runner and a significant part of the guy rope (the ring and the runner do not need to be included in the UV test).</p> <p>Traction must be applied between the tent's roof canvas and the guy rope.</p>	

1.8 Specifications for hammer	
Type:	Sledge hammer, 1kg head, with 30cm wooden handle. In accordance with ISO 15601 and the specification listed below.

Handle:	No chips, rough surfaces, holes or knots. Smooth surface. Strong dry flexible wood. Handle adjusted to head in order to protrude on other side of the head, and be blocked with a metal wedge; or have a conical shape (like a hoe). Moisture minimum 10% and maximum 15%, under ISO 3130.
Pull apart test:	Clamp head in a vice jaw after two series of 25 vigorous blows from varying delivery angles. Apply traction of 500N while trying to pull out the handle; there should be no damage to the hammer's head or handle, and the handle should remain firmly attached to the head.

Specifications part 2: General points for finished product

Performances

The final product must be able to withstand a 75km/h wind without any damage and remain securely attached to the ground without any loss of tension.

When closed, the tent must provide good protection against dust, wind, rain, snow, insects and small crawling fauna.

Minimum roof-load must be 300N/m² under ISO 8937 (snow load for camping tent).

The recommended packed-tent weight is 55kg.

Seams and stitching

All seams that are subject to possible tension must be double lock stitched and waterproofed. Stitching produces strong, long-lasting, neat and professional looking seams.

The stitch count as well as UV and rot-proof sewing threads must be appropriate and suited to the fabric. Stitching must provide strong, waterproof seams with at least the same lifespan as the tent.

The seams must be oriented to facilitate the unimpeded runoff of rain: avoid creating water lines or water pockets.

Wherever possible, the colour of the sewing thread should be compatible with the fabric colour.

Ropes, webbing bands, toggles, loops, reinforcement nettings and all other accessories

All ropes and webbing bands must be heat cut. All ropes are knotted to the tent at the factory. All of the above-mentioned items must be rot-proof and UV-proof (to the same degree as the tent canvas to which they are sewn). To avoid water penetration through capillarity action, no webbing or rope can be sewn using a stitch that goes from the outside to the inside of the tent; alternatively, they must be made of waterproof materials.

Outer-tent laces and loops can be made of the same canvas as the tent roof or walls, and inner-tent loops can be made of the same canvas to which they are sewn.

Zip fasteners

All the zip fasteners must conform to a resistance of 700N lateral traction under ISO 5912.

Eyelets

All metal eyelets must be rustproof and correctly placed, reinforced with a fabric patch and have a minimum inner diameter of 10mm.

Metal rings

All metal rings must be rustproof, galvanized and welded closed.

Dimensional tolerance

Unless otherwise specified, a maximum tolerance of +/- 3% is accepted on all dimensions.

Long-term storage

The tent must be treated and packed in such a way that the tent can be stored for a 5-year minimum under proper storage conditions without any damage or reduction in performance.

The tent must be manufactured and packed in clean and appropriate conditions to avoid contamination from soil, dust and other contaminants.

Specifications part 3: Characteristics of the outer tent

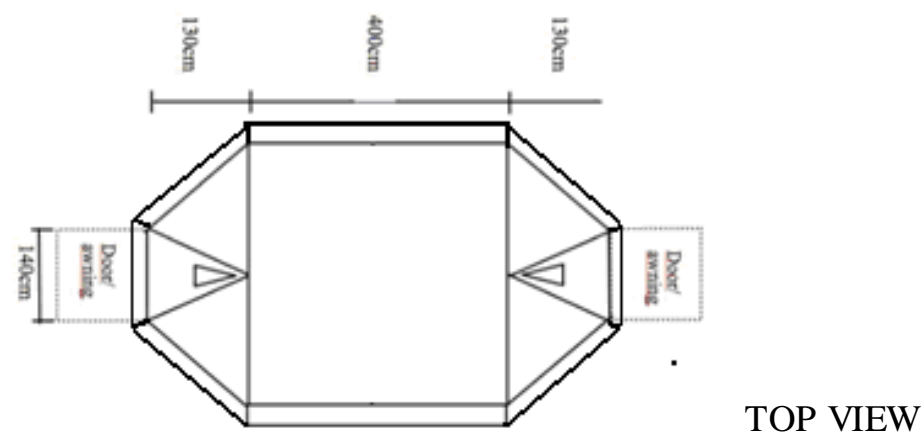
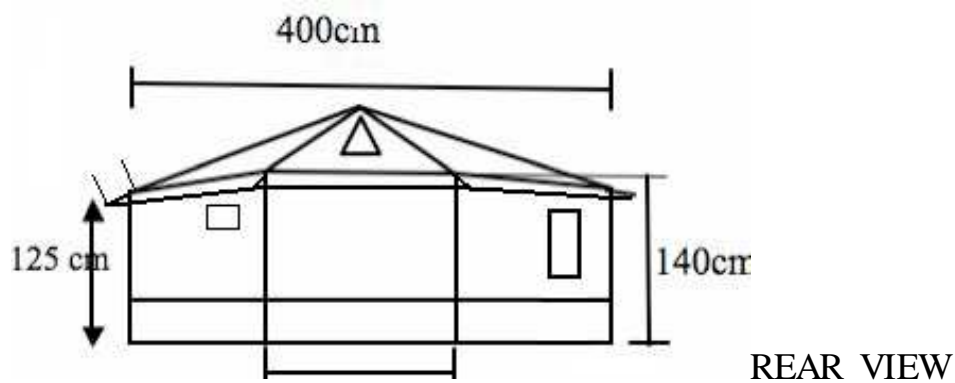
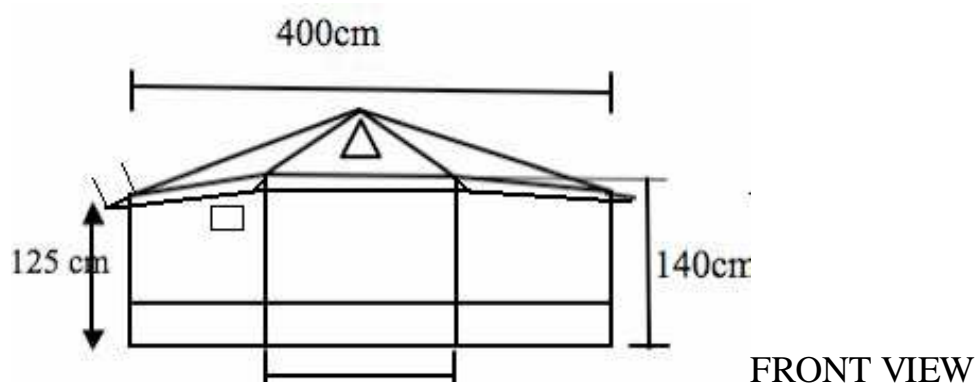

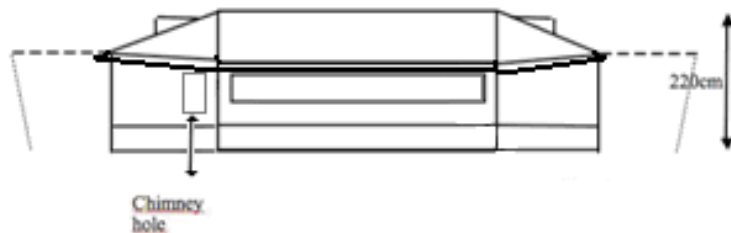

SIDE VIEW

3/1 General description of outer tent

The outer tent must be comprised of several cloth sections, forming the general shape of the tent. The seams must run from the ridge down to the edges of the roof, perpendicular to the ridge line.

The outer tent must be supported by 3 upright poles, 1 ridge pipe, 6 side poles, 4 door poles, 3 guy ropes on each side, and 2 guy ropes at each end. The attachment points for each guy rope must be reinforced.

3/2 Dimensions / erecting system

Centre height:	2.2m
Width:	4m
Ridge length:	4m
Side wall height:	1.25m
Door height:	1.4m
Centre base length:	6.5m

The outer tent must rest on the ridge pipe supported by 3 upright poles, one at each end and in the middle of the ridge pipe. The outer tent must be maintained in position on the ridge pipe by 2 100mm-long canvas sleeves with a Velcro fastening running the full 100mm length; the sleeves are placed 200mm from each end of the ridge pipe.

The side walls must be supported by 6 poles; metal hooks on the top of the poles hook into eyelets in the webbing band (25mm wide) sewn to the top of the wall on the inside. Side-wall poles must not protrude through the outer tent. The hooks at the top of the side poles must be as flat as possible.

The front and back vestibules must be supported by 2 poles at the top corners of the doors, with pins going into the corresponding eyelets on the roof edge, through the guy point webbing.

3/3 Reinforcements

The 10 guy points on the roof must be made of 50mm-wide polyester straps, and be sewn to the eave (an extension of the roof). The eave must be made of a double fold of roof canvas, 200mm in width, and run the perimeter of the tent roof, including above the doors. The eave must be part of the roof panel, without any break (seam) in the canvas. On the 6 guy points located on the sides of the tent, an additional layer of PVC-coated canvas must be added on the inside to protect against abrasion from the tops of the poles.



Additionally, the 6 guy points on the side must be reinforced with a second triangular piece of canvas, 300mm in length (one side), sewn to the edge of the eave with the point extending into the roof section.



The entire length of the ridge must be reinforced on the inside with a 150mm strip, in the same fabric as the roof. The attachment sleeves for the ridge pipe must be sewn to this reinforcement.

3/4 Attachment System (guy lines)

The outer tent must be anchored to the ground using 10 guy lines attached to 10 metal pegs. Each guy point, on both sides of the tent, require a loop made of 50mm-wide webbing. The webbing length allows, when folded in two, for the creation of a 30mm-long loop, at a minimum. This should be stitched to the tent with a strong Z sewing, minimum 50mm in length.

The webbings for the door pole guying points must be 250mm long, in order to cover the tops of the poles and to have the eyelet placed in the webbing.

The 2 central side webbing loops must be sewn perpendicular to the side edges of the tent, the 4 corners webbing loops must make an equal angle with the roof and vestibule edge and the 2 front and 2 rear webbing loops aligned with the vestibule's roof stitching. See drawing.

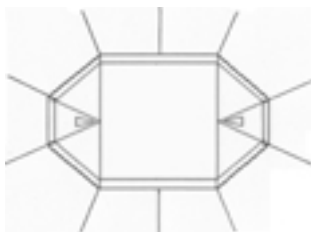

10 metal rings must be attached to the loops with an elastic device. The ropes pass through the 10 metal rings and when tension is applied, the ropes slide through the metal rings.

At the other end, the ropes must have a preformed knotted loop to place over the peg.

The attachment points must be made in such way that they comply with the resistance characteristics specified in part 1.7 of this specification.

3/5 Side windows

The outer tent must have 2 long windows protected with mosquito netting and a rain flap running the length of both sides of the tent. The inside dimensions of the windows must be 3600mm wide by 300mm high; the top edge of the window must be situated 100mm below the roof of the tent. The window openings must be reinforced either with strong reinforced netting (large holes, strong plastic net) or standard netting combined with strips of 20mm polycotton webbing, reinforcing the window horizontally (1 webbing) and vertically (7 webbings). The webbings must be sewn to the edges of the window and to the mosquito netting.

Each window flap must be 3960mm wide x 400mm high and stitched 50mm above the top of the window edge. The flap must have a strip of 25mm-wide Velcro webbing along the length of its vertical sides and its bottom, sewn 25mm from the edge of the window.

Loops and plastic toggles or hooks must be attached to keep the flap open when rolled up.

3/6 Ventilation on top of the vestibules

The outer tent requires 2 ventilation openings, front and back, protected with reinforced netting and a rain flap. The vents must be triangular-shaped and situated at the top of both vestibules. The inside dimensions of the vents must be 250mm wide by 300mm high. The vent flap must be made such that, when opened, it remains distanced from the ventilation opening with a height of 250mm at its centre.

To secure the flap when closed, the cone opening must have a 25mm-wide Velcro strip running its full width.

The vent openings must be reinforced either with strong reinforced netting (large holes, strong plastic net) or standard netting combined with two strips of 20mm cotton or polyester webbing that bisects the vent horizontally and vertically. These webbings must be sewn to the edges of the vent opening and to the netting.



3/7 Outer Tent Doors

Size: 1.3m width x 1.4m high

Door flaps 1.4m width x 1.6m high:

- Upper part 1.4m width x 0.9m high, made of canvas.
- Lower part 1.4m width x 0.7m high, made of woven PE fabric.

The vestibule doors can be used as awnings by moving the front door poles to the 2 eyelets situated at the bottom corners of the doors. Rolled up, door must be held in place by 2 loops and 2 plastic toggles or hooks.

The doors must close with a lacing system. The loops of the lacing system must be made of 4mm rope or canvas strips (7 loops and eyelets per door side). The lacing system requires a toggle or hook in order to attach the last loop.

The lacing system must be protected by a doubled 50mm-canvas flap to prevent rain and draughts.

Each door must be constructed such that one side closes from the inside and the other from the outside.



3/8 Side walls, vestibule walls, mud flaps

Total height 1.45m; i.e., a 1.25m vertical length plus a 0.2m overlay which rests on the ground.

The upper part (top 0.75m) of the walls must be made of a polyester-cotton fabric and the lower part (0.7m) of PE fabric.

The mud flaps must be equipped with 22 eyelets (7 on each side including the corners, 2 on each vestibule side) placed on a strip of 50mm-wide webbing running the full-length of the flap (the entire perimeter of the tent); the webbing must be sewn or heat-sealed to the mud flap on the inside at floor level. The thread and stitch length must be appropriate to the materials to avoid tearing along the stitching (not applicable if heat-sealed). The 2 eyelets on the vestibule side mud flap must be placed one next to the door, and one half-way between the door and the tent corner.

The outer tent must be attached to the side poles with webbings or canvas strings; these must be stitched to the inner side of the outer tent where the PE joins the polycotton and in front of each side and door pole (10 points in total).



The vestibule walls must be made in the same way as the side walls, to complete the outer tent between the doors and the side walls. One of the vestibule walls requires a reinforced chimney hole.



3/9 Chimney reinforcement

A chimney reinforcement (non-perforated) must be located 0.5m from a corner at either end of the tent, between the side-wall corner and its adjacent tent-door corner. It must be made of heat-resistant fabric (minimum 900°C). The type of fabric in which the fibres do not loosen and do not tear when cut.

The lower edge of the heat-resistant fabric must be 500mm above the ground, where the canvas joins the PE part (a band of canvas of 2 to 3cm is allowed between the PE and the fireproof material).

Net inner dimensions of the fireproof part: 250mm width x 600mm height.

Chimney flap dimensions: 350mm width x 700mm height. The flap must be stitched, along the bottom, at the lower edge of the chimney opening. To secure the flap, it must have a 25mm-wide Velcro webbing sewn along the entire length of its 2 vertical sides and upper end, and sewn to the tent 25mm outside the edge of the chimney opening.

The tent fabric must be cut away completely at the chimney opening. The edges of the chimney opening must be hemmed stitched to the inside.



3/10 Other accessories

Four 30mm-loops must be attached to the inside of the tent where the inner tent doors have corresponding toggles at the top of the inner tent door zips (refer to inner tent door description).

10 D-rings (25mm x 4mm thickness) must be attached inside the outer tent; the inner tent hooks to these D-rings (refer to inner tent description point 4/4): 6 D-rings must be attached to the webbings at the top of each side-pole position, the remaining 4 must be placed in intermediate positions.



6 D-rings, secured by a piece of 25mm-wide webbing, must be sewn to the mud flaps at floor level inside the tent; the inner tent attachment strings hook onto these D-rings.

3/11 Plastic for document pouch

On the outside of each left-hand vestibule wall there must be a clear plastic document sleeve. The material must be made of UV-stabilized polyurethane transparent plastic with a minimum thickness of 0.15mm. The lower edge of the sleeve must be 800mm above the ground. The sleeve must have a rain proof opening on the bottom and the two vertical sides sewn to the tent. The inside dimensions of the sleeve, after sewing, must be 230mm high by 310mm wide.

3/12 Manufacturer identification

Made with a strong textile tag of 10x10cm with durable print, and stitched inside the outer tent, in the vertical seam of one tent corner.

The tag should include the manufacture's name, the batch number and the production's date.

Specifications part 4: Inner tent with ground sheet

4/1 General description

The inner tent must be square-shaped and hang inside the outer tent structure. All dimensions must be designed to ensure a 10cm air gap between the outer and inner tents.

The inner tent must have a chimney reinforcement, 2 windows, 2 doors and 2 vents. The bathtub groundsheet (floor) must be made of woven PE fabric, and be sewn to the inner tent extending up the sides of the wall to ensure the inside remains waterproof. Stitching is not permitted on the lower part of the groundsheet to ensure 100% waterproofing.

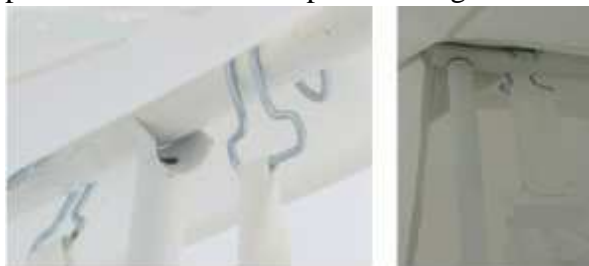

Ridge

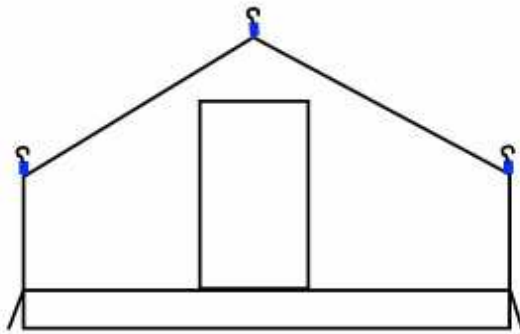

Inner tent front

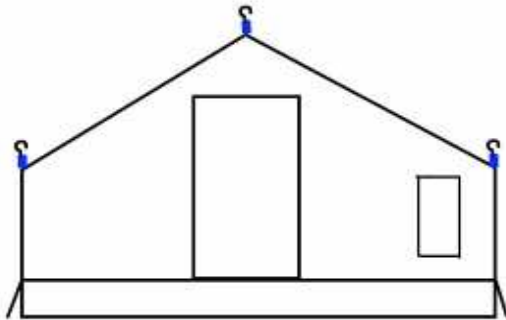

Inner tent rear

4/2 Inner tent dimensions

The inner tent, when hooked to the outer tent, must have a centre height of 2.1m, a width of 3.8m, a wall height of 1.15m and a base length of 3.95m.

4/3 Inner doors

Each door opening must be 1m wide and 1.75m above the floor (1.55m measured from the upper edge of the groundsheet).

Door panels (1.1m wide) must be placed in the centre of the front and rear walls.

A door must be made of the same material as the tent and close with polyester n°10 coil zip fasteners on the 2 vertical sides. The zip fasteners must open from both the inside and outside. The doors must have a 200mm PE flap at the bottom, made of the same material as the groundsheet.

Black UV-stabilized ropes or canvas laces with plastic toggles or hooks must be provided to keep the door opened when rolled up.

Mosquito nets (1.1m wide) must be placed on the inside of the doors. The 2 vertical sides must close with n°10 polyester coil zip fasteners. The bottom edge of the mosquito flap must close with one piece of 25mm-wide Velcro along the entire width.

To facilitate door closing:

- two 80mm-elastic webbing loops with an attached toggle or hook must be placed along the sides of each door, at the top, aligned with the zips. These attach to the corresponding 3cm loops inside the outer tent.
- 2 webbing loops with eyelets must be placed at the bottom of each door, aligned with the zips. These are used to attach the tent to the ground with 6mm x 230mm pegs. The 200mm long webbing loops must be stitched into the seam where the PE joins the fabric.



4/4 Inner Tent Suspension System

The inner tent suspends between the 2 end poles, attached (knotted) by 2 strings or strips, 25mm by 200mm long at each end.

The inner tent must be suspended from the ridge pipe by 8 galvanized 4mm wire hooks mounted on 8 50mm-wide webbing loops. The total length of a loop including its metal hook must be 100mm. One hook must be placed at each end, two in the centre (100mm either side of the centre pole gap) and the 4 remaining hooks equally spaced on each side.

The side walls of the inner tent must hook, using strong plastic or metal hooks mounted on webbing loops, to a corresponding D-rings on the inside of the outer tent, at the top of each side pole and in the intermediate positions. The loops are made of 25mm-wide webbing bands. The complete length of the attachment including the hook must be 100mm. 5 hooks in total per side at the top of the wall. 3 hooks in total per side at the bottom of the wall. The attachment loops are elasticized for the bottom of the wall, there are non-elasticized for the top of the wall.

Elastic webbing bands for the bottom of the walls are stitched to the tent in the seam where the PE and fabric join.

The inner tent must have 28 20mm-loops, made of canvas; these can be used to attach the inner lining or the inner partition - both of which are optional features. The loops must be attached to the inside of the inner tent at every place where the inner tent attaches to the outer tent or to the frame, with an additional 2 loops at the bottom of each door (8 at the ridge, 5 at the top of each side wall, 3 at the bottom of each side wall and 2 at the base of each doors).

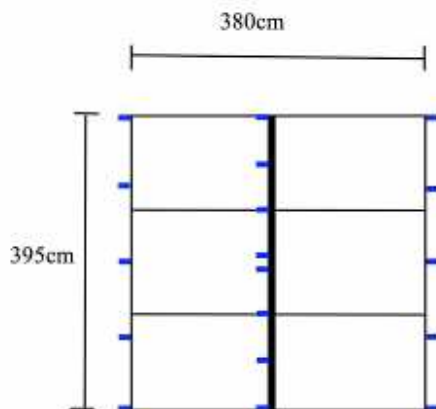

4/5 Inner tent ventilation system

The inner tent has 2 triangular vents in each gable top, made of mosquito netting reinforced with 20mm webbings. The netted triangle must fill the space from the ridge to the top of each door. The ventilation system must close from inside with a flap that rolls downwards, and seal with 25mm-wide Velcro on all sides.

4/6 Inner tent windows

The inner tent has 2 windows of equal size (and reinforcement) that align with the outer tent windows. The flaps, made of the same material as the inner tent, must be sewn from the inside and open downwards. The flaps hang freely when open and close using a 25mm-wide Velcro strip on three sides.

4/7 Accessories inside the inner tent

To hang light-weight items, three 20mm-hooks (mounted on 20cm webbing) and one pouch, made of netting material attached on 3 sides, of 150 x 200mm inner net dimension, must be sewn inside the inner tent at the ridge.

The pouch hangs from the ridge on the same spot as the 2nd ridge suspension hook; the 3 light weight hooks are placed at the same spots as the 3rd, 6th and 7th ridge suspension hooks.

4/8 Groundsheet

The integrated groundsheet must be made of PE woven fabric. The seam, attaching the groundsheet to the sides of the inner tent, must be 200mm above the floor. To avoid water infiltration no stitched seams are permitted, all groundsheet seams must be welded (heat sealed) and have a 25mm overlap. A reinforced patch, 150 x 150mm, of the same material as the groundsheet must be glued or sealed to the centre of the groundsheet to prevent the centre pole from damaging the groundsheet.

The groundsheet must be hooked to the outer tent D-rings with 6 elastic webbings and plastic hooks, 20mm in width.

4/9 Chimney reinforcement

A chimney reinforcement (non-perforated) must be situated 0.5m from one of the tent corners, between the corner of one side wall and the corner of the adjacent tent door. It must be made of heat-resistant fabric (minimum 900°C).

Inside dimensions: 250mm width x 800mm height.

The lower edge of the heat-resistant fabric must be 300mm above the ground.

The tent fabric must be completely cut away from around the chimney opening and the edges hemmed stitched.



4/10 Inner partition

One partition running from either sides of the centre pole to the side walls, constructed from 2 half-partitions, that can be stitched together at the top. The partition is attached to the loops on the inner tent at the roof and wall levels with minimum 6 pairs of string or hooks/toogles with loops, and to the centre pole with 2 pair of string. The partition can be maintained open with 2 additional pair of string or Velcro.



4/11 Safety information tag

Safety information must be available inside the tent in the form of a durable print on a piece of canvas stitched inside the inner tent with the text found in annex at the end of these specification.

Specifications part 5: poles and accessories

5/1 Poles

- Each section should fit together with a male and female 100mm joint, made with a 200mm long inserted pipe point-welded or crimped into one of the pipes (not to be made with press-reduced pipe diameter).

Ridge pipe

- 4m long, galvanized or painted steel pipe with a 30mm-minimum outer diameter and a minimum 1.2mm wall thickness, in 2 or 4 pieces depending on the type of packaging.
- The ends of the ridge pipe must be reinforced with 2 short 100mm-long pipes with an outer diameter of 27.5mm, inserted and point welded at both ends of the ridge.
- 22.5mm-holes drilled 20mm from both ends, into which the upright poles to fit.
- The ends of the ridge pipe must be protected with a plastic cap devoid of sharp or cutting edges.

Upright poles

- 2 upright poles, 2200mm each (end plug included), galvanized or painted steel pipe with a minimum outer diameter of 25mm and minimum 1.2mm wall thickness, in one or two pieces

depending on the type of packaging. The top 40mm of the 2 poles must have a narrower diameter of 21.5mm (end plug included) to insert into the ridge pipe. The top end of the 2 poles must have a protruding plastic bushing to protect the tent from the edges of the pipe.

- The base of the 2 upright poles must have a metal or plastic base plate 50mm in diameter.
- One central and upright 2170m-pole (size without U-bracket), galvanized or painted steel pipe with a minimum 30mm outer diameter and minimum 1.2mm wall thickness, comes in one or two pieces depending on the type of packaging. This pole comes with a 30mm-long U-shaped metal bracket.
- The base of the central pole must have a soft flexible plastic or rubber base plate 50mm in diameter, that will not damage the ground sheet while keeping proper stability..

Side poles

- 6 1.25m-side poles of painted or galvanized steel pipe with a minimum outer diameter of 19mm and a minimum 1mm wall thickness, in one or two pieces depending on the type of packaging. The top of each pole must have a bent 20 to 30mm pin form into a flat hook.
- 4 1.4m-door poles, painted or galvanized steel pipe with a minimum outer diameter of 19mm and a minimum 1mm wall thickness, in one or two pieces depending on the type of packaging.
- The 4 door poles must come with a 50mm pin at the top.
- Side and door pole base plates must be made from a round piece of plastic or metal, 40mm in diameter, with a 20 to 30mm pin pointing downwards.

5/2 Ropes/loops/ guy runners

- 6 ropes, black, UV treated, each 3m long, 8mm diameter, with a minimum tensile strength of 300kg.
- 4 ropes, black, UV treated, each 3m long, 6mm diameter, with a minimum tensile strength of 140kg.
- All ropes must be passed through the tent rings at the factory.
- All ropes must have a securely-knotted loop at one end, to place over the peg.
- Hard-wood or strong UV-proof plastic guy runners, red coloured, pre-mounted on the ropes.
- The grain of the wooden runners must run lengthwise in the runner.
- Size of the runners: 100 x 35 x 12mm for wood runners, 15% less if made of plastic, the holes must be the same diameter as that of the ropes and adapted to the good running and blocking of the supplied ropes.
- The ropes must be threaded through the runners in the position that represents the maximum blocking position on the ropes as per photo below.



5/3 Pegs and accessories

- Six 350mm-pegs, made of angled iron 25 x 25mm and 3mm thick, with a 50mm-iron rod 6mm in diameter welded on top. At one end, both wings of the angled iron must be cut at a 45° angle to form a pointed end. At the other end, both wings of the angled iron must be pressed together until they touch and the 50mm by 8mm rod welded to the top. The rod

produces a 25mm prominence bent downwards slightly. The 6 pegs must have 2 notches on each wing side, but not directly opposite each other, to improve their grip in soft ground. The notches should be approximately 3mm in width with a maximum depth of 3mm.

Pegs are painted or galvanized.

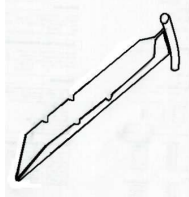

- 4 300mm-pegs including bend, made of iron rebar 10mm in diameter, with a “candy cane” shaped hook on one end, painted or galvanized.
- 26 230mm-pegs, made of iron bar 6mm in diameter, painted or galvanized, with a round shaped head on one end, to avoid damaging the mud flap when pushed through the eyelets.
- 1 1kg-metal hammer with 300mm wooden handle. (refer to specifications in part 1).
- In the accessory bag, 1 set-up instruction sheet in English, showing step by step set-up information drawings and item content list and information, printed on durable laminated paper or durable fabric (see part 7/1)
- 1 repair kit including: 1 needle, 20m stitching thread, 3m polyester rope or string of 3mm used to attach the canvas spare piece around the bundle as per point 6/1 Standard package.

Specifications part 6: Packing

6/1 Standard package

One tent with all its accessories must come packed in one bundle only. The inner tent and the outer tent are folded so that the groundsheet protects the tent and accessories from dirt and moisture.

Before placing it into the outer bag, the bundle must be protected with one additional layer made with a piece of polycotton canvas as per the wall canvas minimum, of 2.3m x 1m. This canvas is attached around the bundle with 3 ropes of 1m and 3mm diameter.

The outer bag is made of the same material as the one used for the mud flaps of the tent.

Total length must not exceed 2250mm maximum, approximate diameter should be 400mm in order to have some extra play to facilitate re-packing.

The metal poles and pegs must be packed in 2 separate bags to avoid damaging other items inside the bundle. Both bags must be made of the same material as the outer bag. The bags must have a closure system that ensures the accessories remain in their bags during transport and handling. Particular care must be taken when packing the pegs to ensure they will not pierce the bag.

The package must be secured with 2 webbing straps on the outside; each strap must have a strong self-locking buckle that will not slide during transport. Each self-locking buckle can be made either with two rectangular buckles of 4mm wire, welded-closed, or with one rectangular buckle and one sliding middle bar, of 4mm steel rod, welded-closed.

The straps must not be sewn to the outer bag.

Each strap provides 2 handles.

The buyer’s markings must be printed on the outside in indelible ink.

The standard international warning sign “protect from water” must be printed on the outside of the package.

6/2 Optional package

The poles can be divided into pieces in order to obtain a package of 1.2m in length. The package must be a polycotton bag of 1.2m x 0.4m x 0.3m with a zip closure. The bundle must be secured with 2 webbing straps, each with a self-locking buckle that will not slide during transport. Each strap provides 2 handles. The straps must not be sewn to the bag. All other aspects as per standard packaging instructions.

Specifications part 7: Annexes

7/1 Instruction sheet

As per document available at:

<http://procurement.ifrc.org/en/Documents/IFRC%20TENT%20INSTRUCTION%20SHEET.pdf>

7/2 Safety instruction tag (refers to point 4.11 above).

The text of the instruction tag is:

- Don't use open fire in the tent, use a stove with flue pipes
- Locate the stove away from the walls, with a protection for the floor
- Make a cut in the fireproof fabric patch to pass the flue pipe
- Maintain always some ventilation, especially when the stove is on use
- When possible, cover the stove with heavy fire resistant material (clay or equivalent)

7/3 Summary of all the printing requirements

The following points, already exposed in the specification above, require printing:

- Manufacturer ID as described in part 3/12
- Safety information tag as described in part 4/11 and in part 7/2
- Instruction sheet as described in part 5/3 and in part 7/1
- Buyer marking on Outer bag as described in part 6/1
- Protect from water on Outer bag as described in part 6/1